

Mass Flow Controller (MFC)/ Mass Flow Meter (MFM) for gases

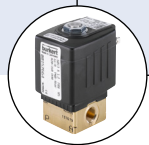

- Nominal flow ranges from 20 I_N/min up to 2500 I_N/min
- High accuracy and repeatability
- Communication via standard signals or Industrial Ethernet
- Electromagnetic and motor-driven valve actuation available
- Easy device exchange through configuration memory

Type 8745 can be combined with...



Type 6013



Type 6027

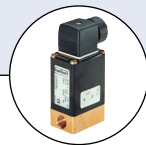

Type 0330



Type 0290

The MFC / MFM type 8745 is suitable for the mass flow control of high flow rates. Type 8746 can be configured as MFM or MFC. Optional, four different gases can be calibrated.

The thermal inline sensor is located directly in the main gas stream and therefore reaches very fast response times. A direct-acting proportional valve as regulating unit guarantees high sensitivity. The integrated PI controller ensures outstanding control characteristics of the MFC / MFM.

MFC Type 8745 is available in two versions: with electromagnetic proportional valve and with motor-driven proportional valve.

Technical data	
Operating medium	Neutral, non-contaminated gases, others on request
Calibration medium	Operating gas or air with correction function
Medium temperature	-10 °C ¹⁾ to +70 °C (-10 °C ¹⁾ to +60 °C with oxygen)
Ambient temperature	-10 °C to +50 °C (higher temperatures on request)
Materials	Body: Stainless steel or aluminium Housing: PC (Polycarbonate) Seals: FKM or EPDM (depending on gas) ²⁾
Port connection	G or NPT ¼", ⅜", ½", ¾", 1" Sub-base
Operating voltage	24 V DC
Voltage tolerance	±10 %
Residual ripple	±2 %
Configuration memory (included in delivery)	EEPROM (µSIM card: bus relevant data and information about spec. control loop in order to ease replacement)
Installation	Horizontal or vertical
Software tool	Bürkert Communicator
Electrical connection	
Industrial Ethernet	PROFINET, Ethernet/IP, EtherCAT, Modbus-TCP via 2 x RJ45 (Switch) ³⁾
Analog	4-20 mA, 0-20 mA, 0-10 V or 0-5 V via D-Sub 9 ⁴⁾ or terminal block
Input impedance	>20 kΩ (voltage), <300 Ω (current)
Max. current (voltage output)	10 mA
Max. load (current output)	600 Ω

¹⁾ When using a motor valve the minimum medium temperature is 0 °C.

²⁾ When using a motor valve additionally:

- Type 3280 DN4: Seat seal in PEEK

- Type 3285: Seat seal in Al₂O₃

³⁾ Supply voltage via separate terminal block.

⁴⁾ The analog version with D-Sub9 features an additional digital input and a relay output.

Nom. flow ranges of typical gases

Gas (other gases on request)	Min. Q_{nom} [l_N/min]	Max. Q_{nom} [l_N/min]
Acetylene	20	975
Ammonia	8	1000
Argon	20	1600
Carbon dioxide	20	800
Air, Oxygen, Nitrogen	20	2500
Methane	20	400
Propane	20	400

Technical data: Type 8745 with solenoid proportional valve

Type 8745 can be configured as MFM or MFC. For MFCs the direct-acting proportional valves of Types 287x are used. These solenoid proportional valves are normally closed and stand for highest accuracy and repeatability with settling/response times of a few hundred milliseconds.

Technical data	
Nominal flow range (Q_{nom})	20...1500 l_N/min (N_2), MFM up to 2500 l_N/min (N_2)
Turndown ratio	50:1 ⁵⁾
Max. operating pressure Data in overpressure to atmospheric pressure	10 bar (with MFCs the max. pressure depends on the orifice of the valve) optional up to 25 bar for MFM
Accuracy	±1.5 % o.R. ±0.3 % F.S. (after 15 min. warm up time)
Repeatability	±0.1 % F.S.
Settling/Response time (t95 %)	<500 ms
Proportional valve (solenoid) Valve orifice range K_{vs} value range	normally closed 0.8 ... 12 mm 0.02...2.5 m^3/h
Power consumption⁶⁾	Max. 4 W (as MFM) Max. 12.5 ... 31.5 W (as MFC, depending on proportional valve type)
Protection class	IP20
Dimensions	See pages 5-7
Total weight	ca. 1.8 kg (AI, 16 W valve), ca. 3.1 kg (VA, 16 W valve)
Device status	RGB-LED based on NAMUR NE107

⁵⁾ With vertical installation and flow downwards the turndown ratio is 10:1

⁶⁾ Referring to the typical power consumption (at 23 °C ambient temperature, nominal flow and 30 min. regular operation) The data according to UL 61010-1 may differ (see manual)

Technical data: Type 8745 with motor-driven proportional valve

The Type 8745 with motor-driven valves is especially designed for applications with high inlet pressures of up to 22 bars or high flow rates (at a low pressure drop). The motor's power consumption to hold a specific opening position is nearly zero. This key feature can reduce the energy consumption of a plant dramatically. Without electrical power the valve remains in its current position.

The maximum duty cycle of the motor depends on the ambient temperature. The duty cycle does not refer to the duty cycle of the device but to the duty cycle of the motor. The motor is not switched on unless the valve is to move. Frequent set-point value changes will drastically increase the duty cycle of the motor.

Derating curve for Type 8745 with motor valve

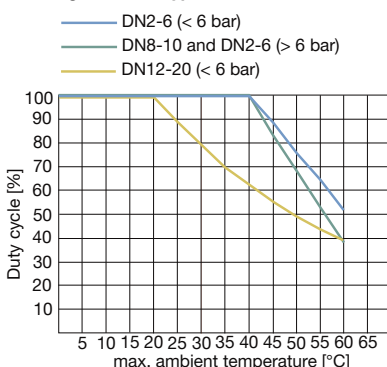

Technical data	
Nominal flow range (Q_{nom})	20...2500 l_N/min (N_2)
Turndown ratio	50:1 ⁷⁾
Max. operating pressure Data in overpressure to atmospheric pressure	22 bar (with MFCs the max. pressure depends on the orifice of the valve)
Accuracy	±2 % o.R. ±0.5 % F.S. (after 15 min. warm up time)
Repeatability	±0.5 % F.S.
Settling/Response time (t95 %)	<5 sec.
Proportional valve (motor-driven) Valve orifice range K_{vs} value range	normally persistent 2...20 mm 0.5...7.8 m^3/h
Power consumption⁸⁾	Max. 4 W (as MFM) Max. 12 W (as MFC) ⁸⁾
Protection class	IP20
Dimensions	See pages 8-9
Total weight	ca. 1.67 kg (AI, standard, valve 3280), ca. 2.94 kg (VA, standard, valve 3280)
Device status⁹⁾	For MFM: RGB-LED acc. to NAMUR NE107 For valve: RGB-LED to indicate the valve opening

⁷⁾ With vertical installation and flow downwards the turndown ratio is 10:1

⁸⁾ Data during moving of the valve. The power to hold a specific valve opening <1 W

⁹⁾ Detailed description of the LED colours: see manual

Pressure Loss Diagram of a MFM (ref. to air)

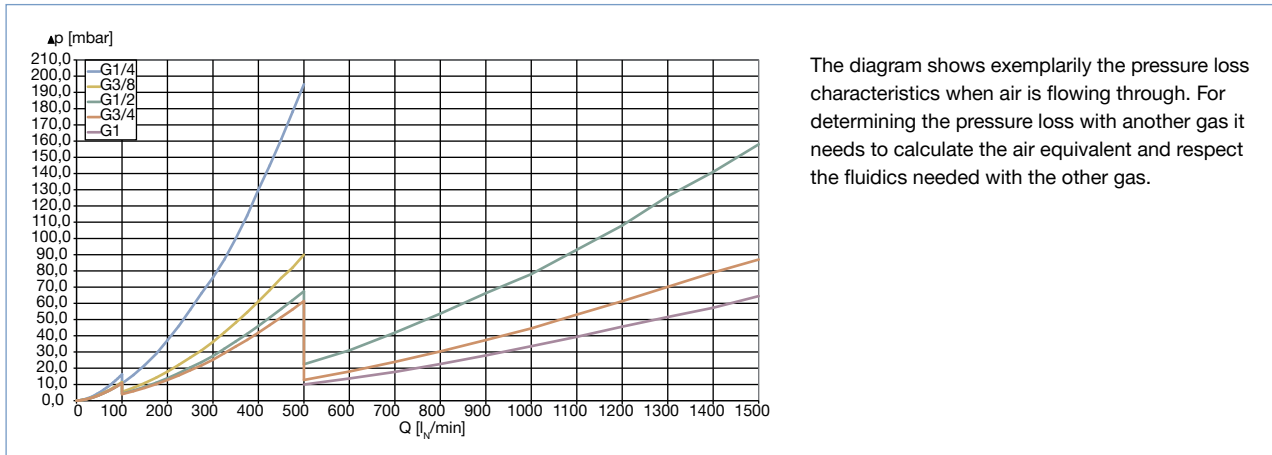

Notes Regarding the Configuration

For the proper choice of the actuator orifice within the MFC, not only should the required maximum flow rate Q_{nom} be known, but also the pressure values directly before and after the MFC (p_1 , p_2) at this flow rate Q_{nom} should be known.

In general, these pressures are not the same as the overall inlet and outlet pressures of the whole plant, because usually there are additional flow resistors (tubing, additional shut-off valves, nozzles etc.) present both before and after the controller. Please use the request for quotation form on p. 11 to indicate the pressures directly before

and after the MFC. If these should be unknown or not accessible to a measurement, estimates are to be made by taking into account the approximate pressure drops over the flow resistors before and after the MFC, respectively, at a flow rate of Q_{nom} . In addition, please quote the maximum inlet pressure $p_{1,max}$ to be encountered. This data is needed to make sure the actuator is able to provide a close-tight function within all the specified modes of operation.

- ▶ The request form on page 11 contains the relevant fluid specification. Using the experience of Bürkert engineers already in the design phase provide us with a copy of the request containing the necessary data together with your inquiry or order.

Measuring Principle

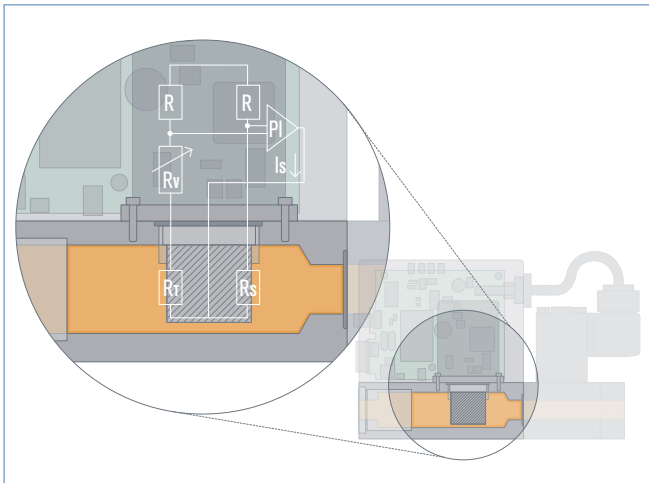

This sensor works as a hot-film anemometer in the so called CTA operational mode (Constant Temperature Anemometer). To do this, two resistors with precisely specified temperature coefficients located directly in the media flow and three resistors located outside the flow are connected together to form a bridge.

The first resistor in the gas flow (RT) measures the fluid temperature, while the second, low value resistor (RS) is heated so that it is maintained at a fixed, predefined overtemperature with respect to the fluid temperature. The heating current required to maintain this is a measure of the heat being removed by the flowing gas, and represents the primary measurement.

An adequate flow conditioning within the MFC and the calibration with high quality flow standards ensure that the mass of gas flowing per time unit can be derived from the primary signal with high accuracy.

Pin Assignment

8745 Industrial Ethernet

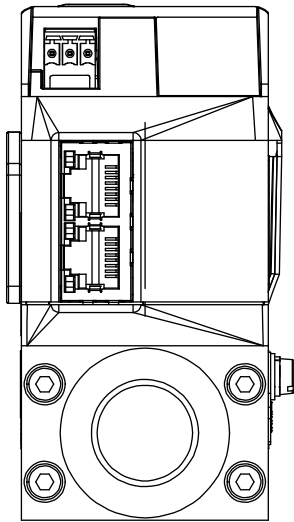

Terminal block 3 pin	Pin	Assignment
	1	FE (Functional earth)
	2	DGND
	3	+24 V DC
RJ45 socket	Pin	Assignment
	1	TX +
	2	TX -
	3	RX +
	4	not connected
	5	not connected
	6	RX -
	7	not connected
	8	not connected
Body	SHIELD	

8745 Analogue

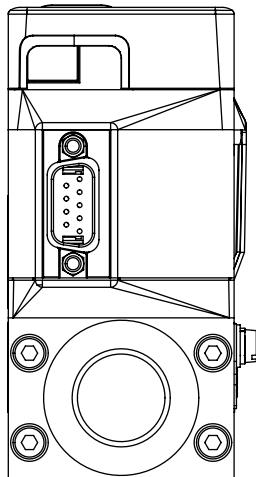

D-Sub 9 pin, plug	Pin	Assignment
	1	Digital input
	2	GND
	3	+24 V DC
	4	Relay - Opener
	5	Relay - Reference contact
	6	Set value input +
	7	Set value input GND
	8	Actual value output
	9	Actual value output GND
Body	SHIELD	

8745 Analogue

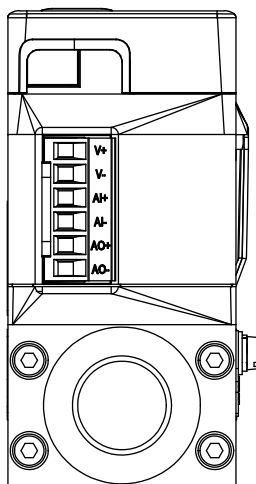

Terminal block 6 pin	Pin	Assignment
	1	+24 V DC
	2	GND
	3	Set value input +
	4	Set value input GND
	5	Actual value output +
	6	Actual value outputGND

Dimensions [mm] Type 8745

MFC with valve Type 2873 (9 W coil)

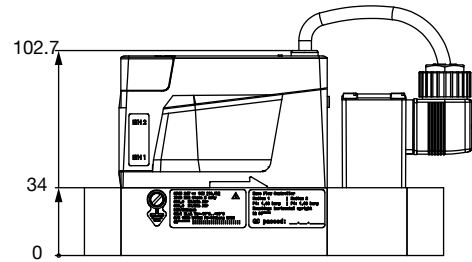
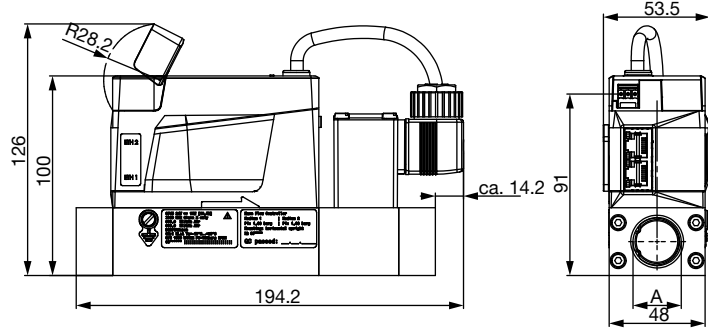
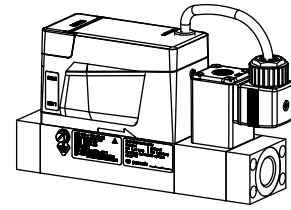
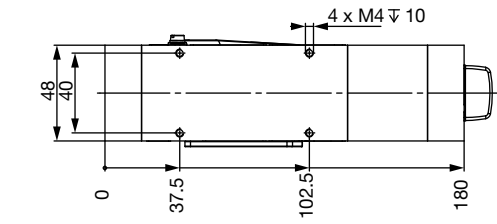

A	Thread depth
G ¼	12
NPT ¼	11
G ⅜	12
NPT ⅜	11
G ½	15
NPT ½	14
G ¾	16
NPT ¾	15

MFC with valve Type 2875 (16 W coil)

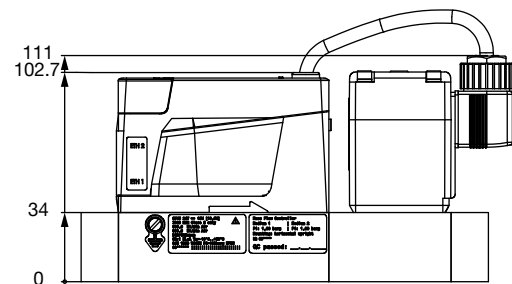
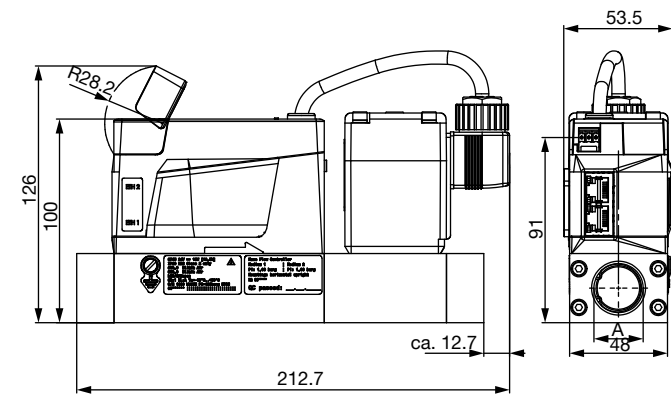
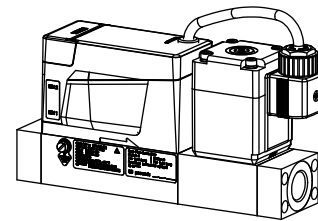
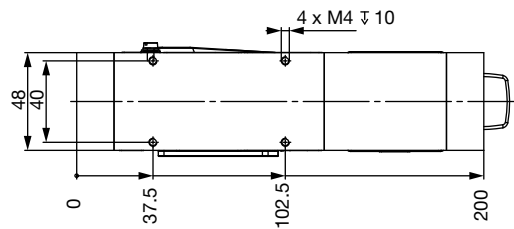

Dimensions [mm] Type 8745

MFC with valve Type 2836 (24 W coil)

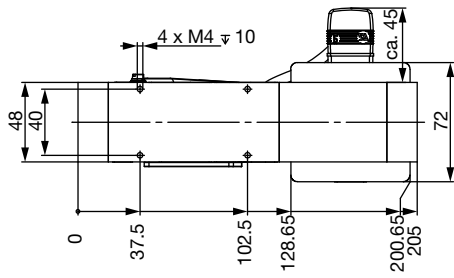

A	Thread depth
G 1/4	12
NPT 1/4	11
G 3/8	12
NPT 3/8	11
G 1/2	15
NPT 1/2	14
G 3/4	16
NPT 3/4	15

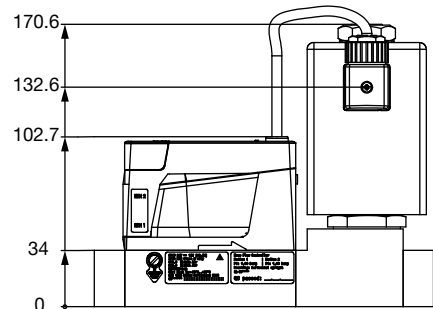
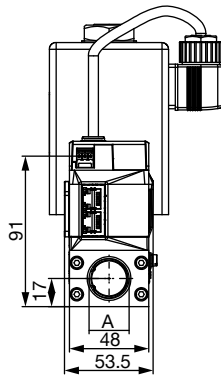
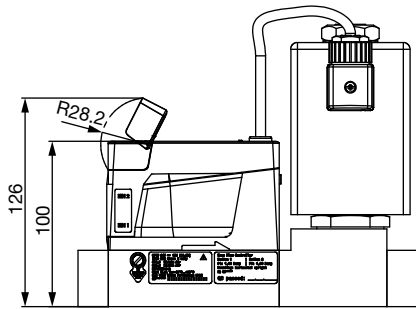
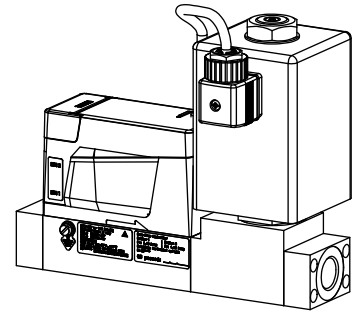

Version with base block for large nominal flow rates

For a nominal flow $Q_{nom} > 1500 \text{ l}_N/\text{min}$ the overall length increases by 30 mm

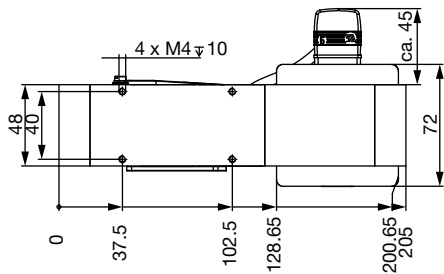

A	Thread depth
G 1/2	15
NPT 1/2	14
G 3/4	16
NPT 3/4	15
G 1	18
NPT 1	16.8

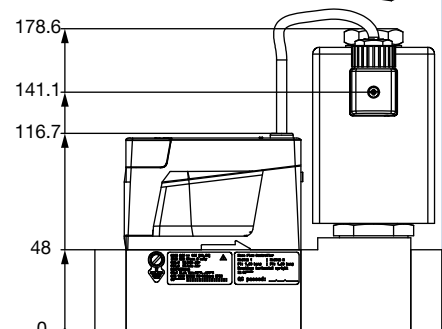
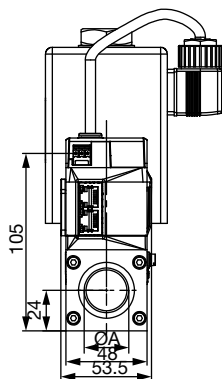
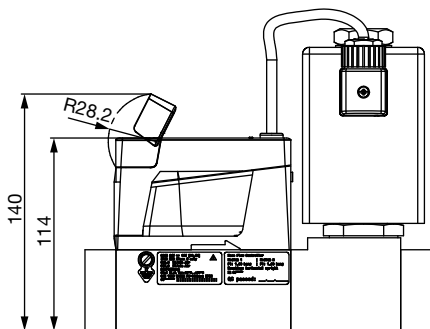
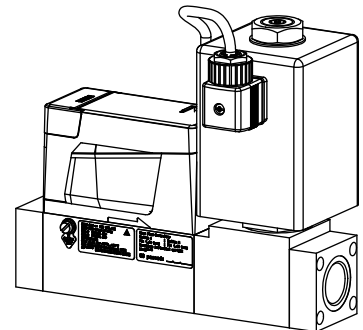

Dimensions [mm] Type 8745

MFM version

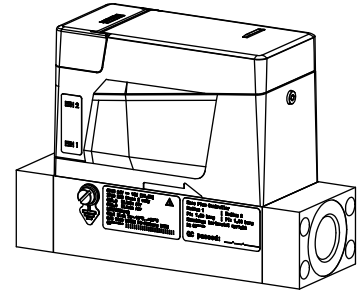
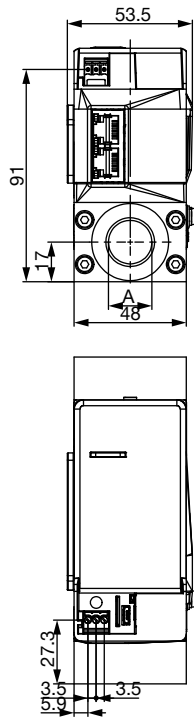
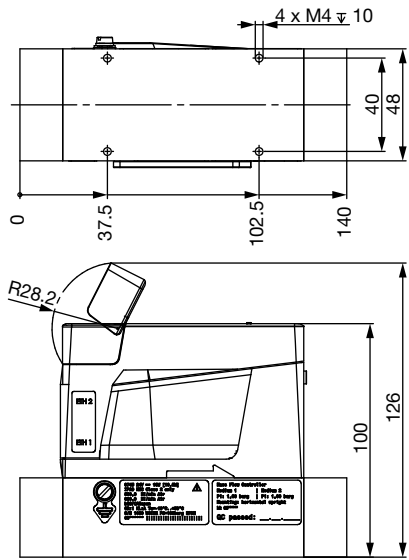

A	Thread depth
G ¼	12
NPT ¼	11
G ⅜	12
NPT ⅜	11
G ½	15
NPT ½	14
G ¾	16
NPT ¾	15

Version with base block for large nominal flow rates

For a nominal flow $Q_{nom} > 1500 l_N/min$ the overall length increases by 30 mm

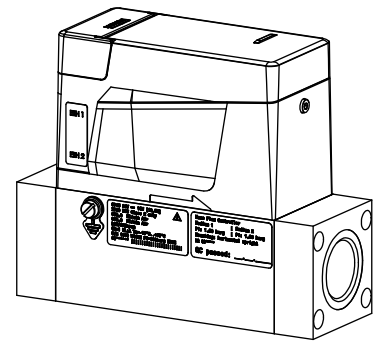
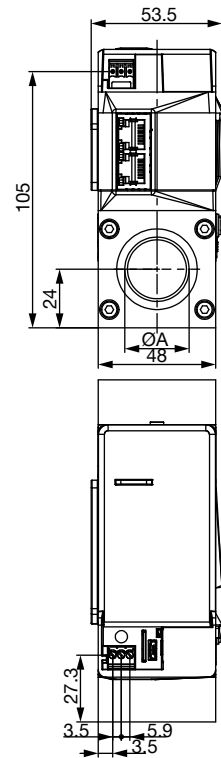
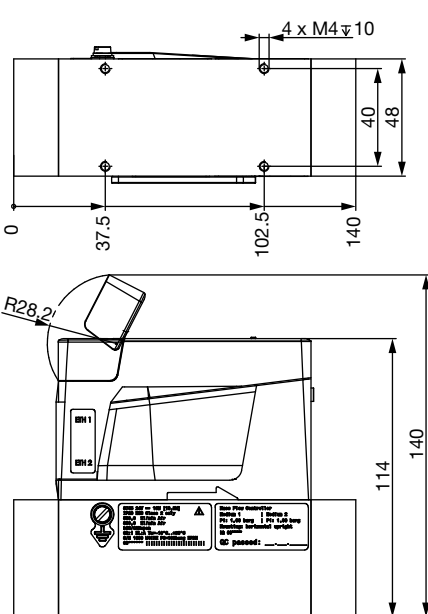

A	Thread depth
G ½	15
NPT ½	14
G ¾	16
NPT ¾	15
G 1	18
NPT 1	16.8

Dimensions [mm] Type 8745

MFC with valve Type 3280

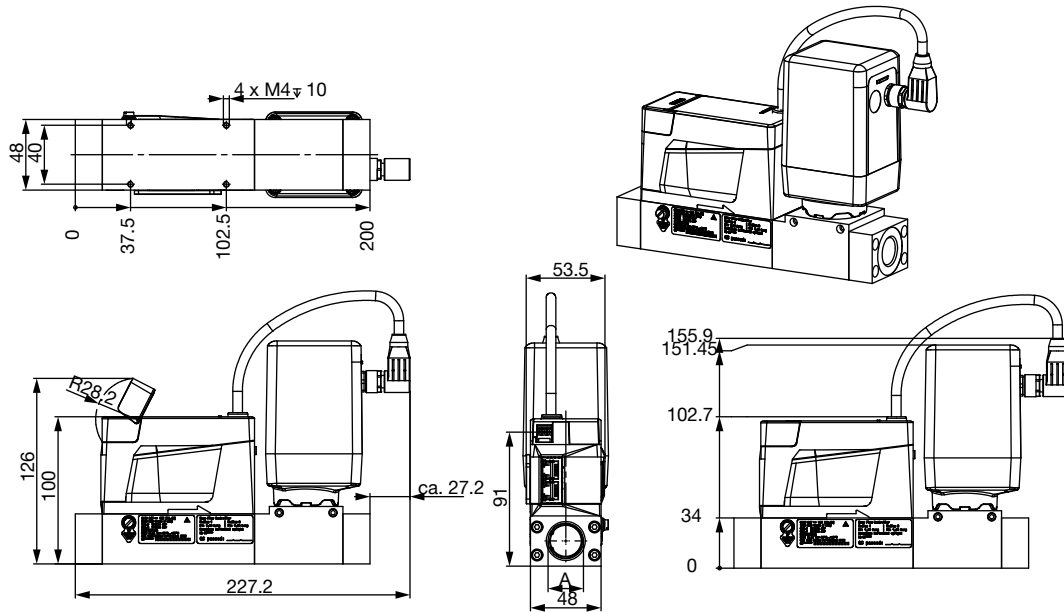

A	Thread depth
G ¼	12
NPT ¼	11
G ¾	12
NPT ¾	11
G ½	15
NPT ½	14
G ¾	16
NPT ¾	15

A	Thread depth
G ½	15
NPT ½	14
G ¾	16
NPT ¾	15
G 1	18
NPT 1	16.8

Version with base block for large nominal flow rates

For a nominal flow $Q_{nom} > 1500 \text{ l}_N/\text{min}$ the overall length increases by 30 mm

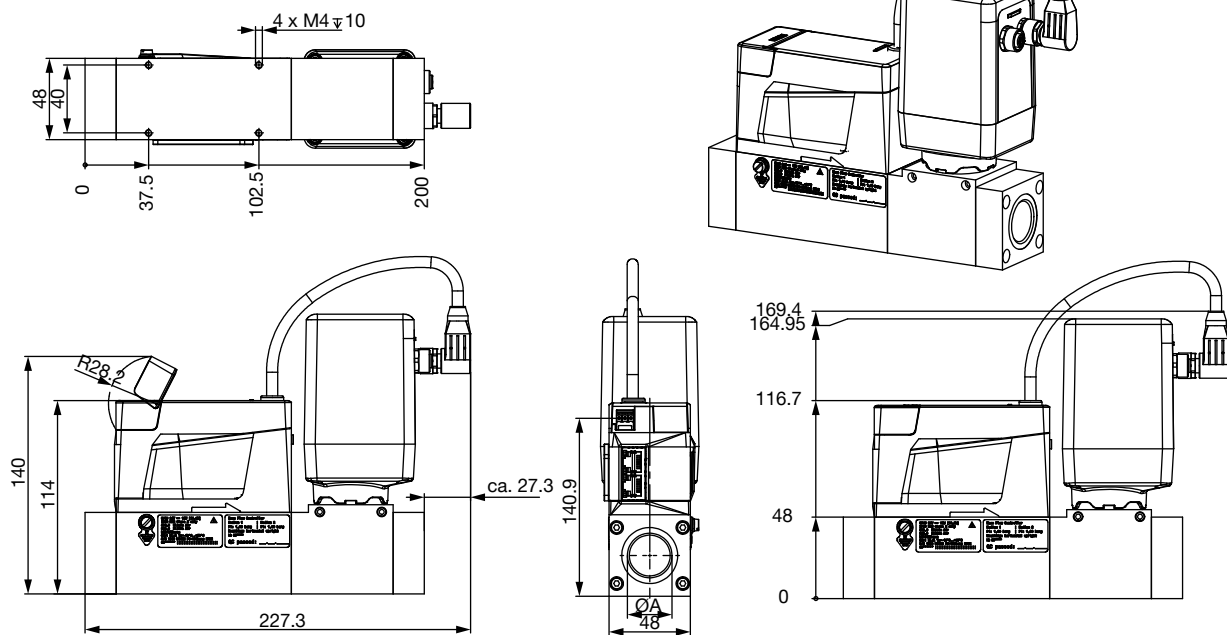

Dimensions [mm] Type 8745

MFC with valve Type 3285

Valve orifice DN12 and DN15

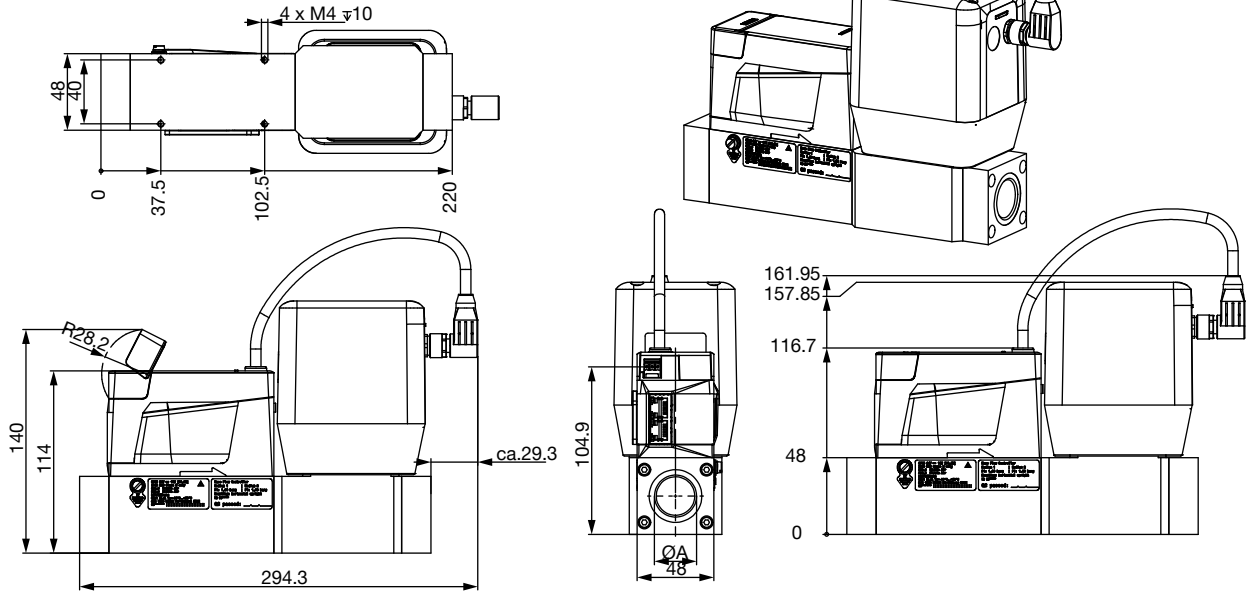

A	Thread depth
G 1/2	15
NPT 1/2	14
G 3/4	16
NPT 3/4	15
G 1	18
NPT 1	16.8

Valve orifice DN12 and DN15

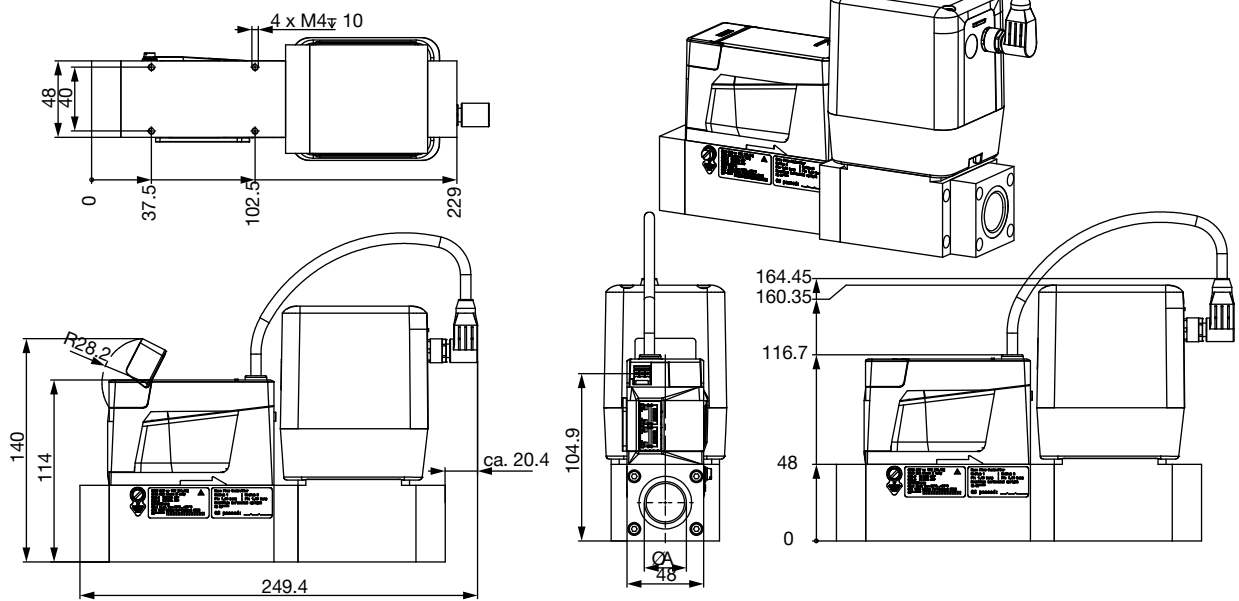

Version with base block for large nominal flow rates

For a nominal flow $Q_{nom} > 1500 \text{ l}_N/\text{min}$ the overall length increases by 30 mm

Ordering Chart for Accessories

Article	Article no.
büS-Stick Set 2 (incl. cable (M12 and Micro-USB), Stick with integrated terminating resistor)	772551
Power supply Type 1573 for rail mounting, 100...240 V AC/ 24 V DC, 1.25 A, NEC Class 2 (UL 1310)	772438
Power supply Type 1573 for rail mounting, 100...240 V AC/ 24 V DC, 1 A, NEC Class 2 (UL 1310)	772361
Power supply Type 1573 for rail mounting, 100...240 V AC/ 24 V DC, 2 A, NEC Class 2 (UL 1310)	772362
Power supply Type 1573 for rail mounting, 100...240 V AC/ 24 V DC, 4 A	772363
µSIM-Card (included in delivery of MFC)	on request
LabVIEW device driver	on request
Device description files for PROFINET (GSDML), Ethernet/IP (EDS), EtherCAT (ESI)	Download from www.burkert.com
Software Bürkert Communicator	Download from www.burkert.com
For 8745 Analogue	
Terminal block 6 pin (for 8745 Standard; included in delivery of the corresponding analog version)	on request
Connector cable D-Sub 9 to leads, 5 m	580882
Connector cable D-Sub 9 to leads, 10 m	580883

To connect the MFC / MFM with the „Bürkert Communicator“ software tool, you need a büS-stick. The connection is made via the micro-USB socket on the device (büS-Stick Set 2 contains the necessary accessories).

Attention: The interface to the „Bürkert Communicator“ software tool is based on CANopen. The appropriate bus termination is mandatory. Hence, please activate the connectible termination resistor on the büS-Stick.

Software Bürkert Communicator

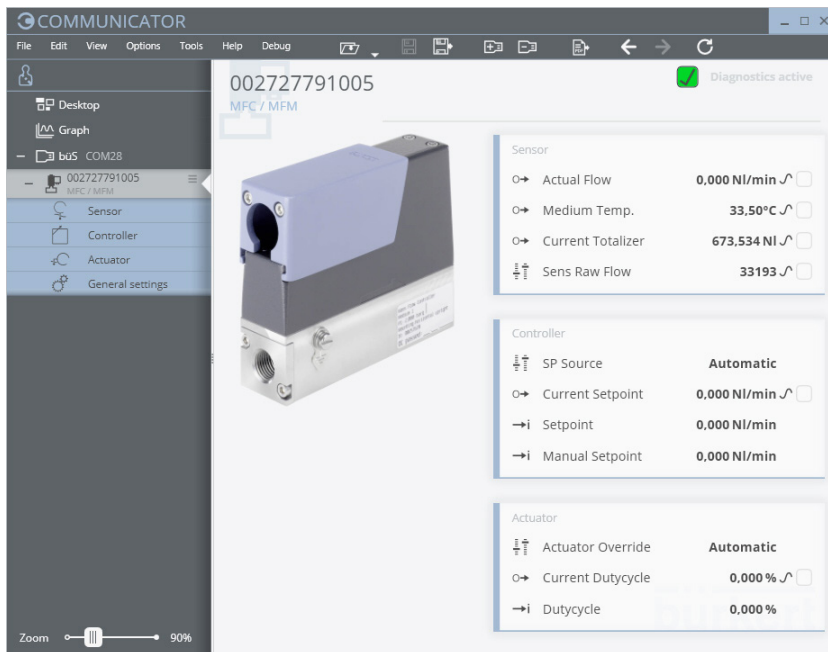

To install the software, click on the download button.

Part of Bürkert's new EDIP program (Efficient Device Integration Platform) is the Bürkert Communicator. This software can be run under MS-Windows and it is available on Bürkert's website for free. The Bürkert Communicator allows convenient system configuration and parameterization of all connected field devices. An accessory part, the büS stick – please see ordering chart for accessories – serves as the interface between computer and process instruments. It transfers "USB data" to "CAN data". The Communicator allows:

- Diagnosis - Parameterization - Registration and storage of process data. The Communicator allows:
- Diagnosis
- Parameterization
- Registration and storage of process data
- Data logging
- To watch graph of process
- To update firmware of the büS device connected
- To program system controls by User-f(x) – e.g. gas blending
- Guided re-calibration
- ...

MFC/MFM applications - Request for quotation

▶ Please complete and send to your nearest Bürkert sales centre

Company	Contact person
Customer No.	Department
Address	Tel./Fax
Postcode/Town	E-Mail

 MFC Application MFM Application Quantity Required delivery date

 Preferred valve type: electromagnetic (highly dynamic) motor-driven (energy saving)

Medium data

Type of gas (or gas proportion in mixtures)

Density kg/m³¹⁰⁾

Gas temperature [°C or °F] °C °F

Moisture content g/m³

Abrasive components/solid particles no yes, as follows:

Fluidic data

Flow range Q_{nom}

<input type="text"/>	Min.	<input type="checkbox"/> l _v /min ¹⁰⁾	<input type="checkbox"/> l _g /min (slpm) ¹¹⁾
<input type="text"/>	Max.	<input type="checkbox"/> m _N ³ /h ¹⁰⁾	<input type="checkbox"/> kg/h
		<input type="checkbox"/> cm _N ³ /min ¹⁰⁾	<input type="checkbox"/> cm _S ³ /min (sccm) ¹¹⁾
		<input type="checkbox"/> l _v /h ¹⁰⁾	<input type="checkbox"/> l _g /h ¹¹⁾

Inlet pressure at Q_{nom} ¹³⁾ $p_1 =$ bar(g) •

Outlet pressure at Q_{nom} $p_2 =$ bar(g) •

Max. inlet pressure P_{1max} bar(g) •

MFC/MFM port connection

without screw-in fitting

<input type="checkbox"/> ¼" G-thread (DIN ISO 228/1)	<input type="checkbox"/> ¼" NPT-thread (ANSI B1.2)
<input type="checkbox"/> ⅜" G-thread (DIN ISO 228/1)	<input type="checkbox"/> ⅜" NPT-thread (ANSI B1.2)
<input type="checkbox"/> ½" G-thread (DIN ISO 228/1)	<input type="checkbox"/> ½" NPT-thread (ANSI B1.2)
<input type="checkbox"/> ¾" G-thread (DIN ISO 228/1)	<input type="checkbox"/> ¾" NPT-thread (ANSI B1.2)
<input type="checkbox"/> 1" G-thread (DIN ISO 228/1)	<input type="checkbox"/> 1" NPT-thread (ANSI B1.2)

with screw-in fitting (acc. to specification for pipeline)

mm pipeline (external Ø)

inch pipeline (external Ø)

Sub-base

Installation

horizontal

vertical, flow upwards vertical, flow downwards

Ambient temperature °C

Material data

Body base Aluminium Stainless steel

Seal FKM EPDM

Electrical data

Signals for set point and actual valve

PROFINET Ethernet/IP EtherCAT Modbus TCP

4...20 mA 0...20 mA 0...10 V 0...5 V Terminal block version, Default: D-Sub

• Please quote all pressure values as overpressures with respect to atmospheric pressure [bar(g)]

¹⁰⁾ at: 1.013 bar(a) and 0 °C¹¹⁾ at: 1.013 bar(a) and 20 °C¹³⁾ matches with calibration pressure

To find your nearest Bürkert facility, click on the orange box →

www.burkert.com

In case of special application conditions, please consult for advice.

Subject to alteration.
© Christian Bürkert GmbH & Co. KG

1806/4_EU-en_1000338235